

| PARÇA KODU PART CODE | PARÇA ADI PART NAME | s ÖLÇÜSÜ (KALINLIK) s MEASURE (THICKNESS) | Malzeme Material | Kaplama / Coating | | |
|-------------------------|------------------------------|--|-------------------------|-------------------|----|----|
| | | | | SN | AG | Nİ |
| TŞ 2490.60 DP | 2.5 NO 2.TERMİNAL Ø3.2 =DP= | 0.60±0.05 | (CuZn30) Pirinç / Brass | - | - | - |
| TŞ 2490.60 RP | 2.5 NO 2.TERMİNAL Ø3.2 =RP= | 0.60±0.05 | (CuZn30) Pirinç / Brass | - | - | - |
| TŞ 2490.60 RPK | 2.5 NO 2.TERMİNAL Ø3.2 =RPK= | 0.60±0.05 | (CuZn30) Pirinç / Brass | + | - | - |
| TŞ 2490.60 DPK | 2.5 NO 2.TERMİNAL Ø3.2 =DPK= | 0.60±0.05 | (CuZn30) Pirinç / Brass | + | - | - |
| TŞ 2490.80 DP | 2.5 NO 2.TERMİNAL Ø3.2 =DP= | 0.80±0.05 | (CuZn30) Pirinç / Brass | - | - | - |
| TŞ 2490.80 RP | 2.5 NO 2.TERMİNAL Ø3.2 =RP= | 0.80±0.05 | (CuZn30) Pirinç / Brass | - | - | - |
| TŞ 2490.80 RPK | 2.5 NO 2.TERMİNAL Ø3.2 =RPK= | 0.80±0.05 | (CuZn30) Pirinç / Brass | + | - | - |
| TŞ 2490.80 DPK | 2.5 NO 2.TERMİNAL Ø3.2 =DPK= | 0.80±0.05 | (CuZn30) Pirinç / Brass | + | - | - |

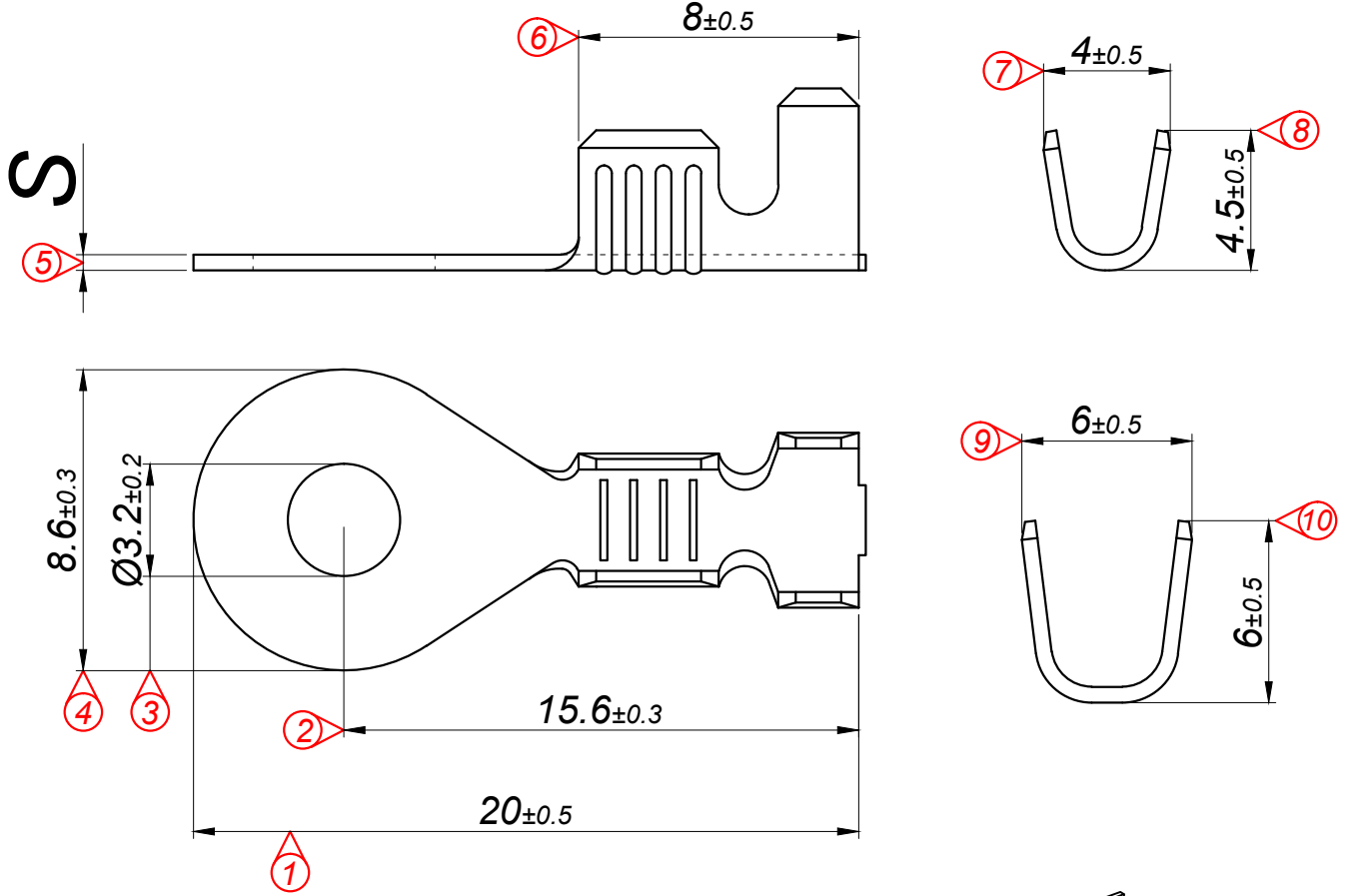

Kalıp çıkış yönü
Mold output direction

Makara açılım yönü
Reel opening direction

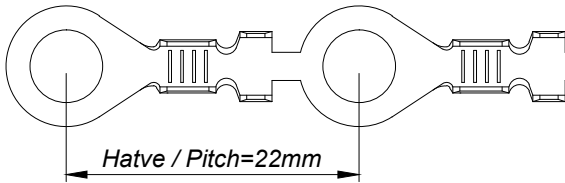

Ölçek
Scale : 2 / 1

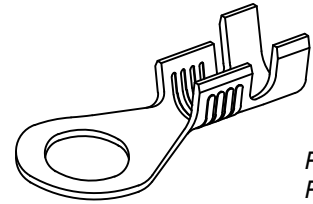

Perspektif
Perspective

Kablo Kesiti

Wire Section : 1 - 2.50 mm²

Resim üzerinden ölçü almayınız
do not measure on drawing

| | | | | | |
|---|-------------------------|------------------------|--------------|--------------------------|------------|
| Tarih / Date | 18.05.2016 | İmza /Signature | Ölçek /Scale | | |
| Çizen / Desing | T.Topçu | | 5 / 1 | | |
| Onay / Approval | S.Gölcük | | No | Değişiklik / Revision | Tarih/Date |
|  | Parça Adı: Part Name | 2.5 NO 2.TERMİNAL Ø3.2 | | Parça Kodu: Part Code | TŞ 2490 |